

Elecraft® KX3

KX3HSMDKT Enhanced Heat Sink

Installation Instructions

Revision A, December 9, 2014

Copyright © 2014, Elecraft, Inc., All Rights Reserved

Introduction

The enhanced heat sink improves the heat dissipation of the final amplifier transistors improving performance without significantly increasing the rig's size or weight.

The enhanced heat sink is thicker than the original and wraps around the bottom of the KX3 as shown in Figure 1. The additional mass and area of this heat sink provides as much as twice the operating time at full power before the KX3's protective circuitry automatically reduces the power to 5 watts.

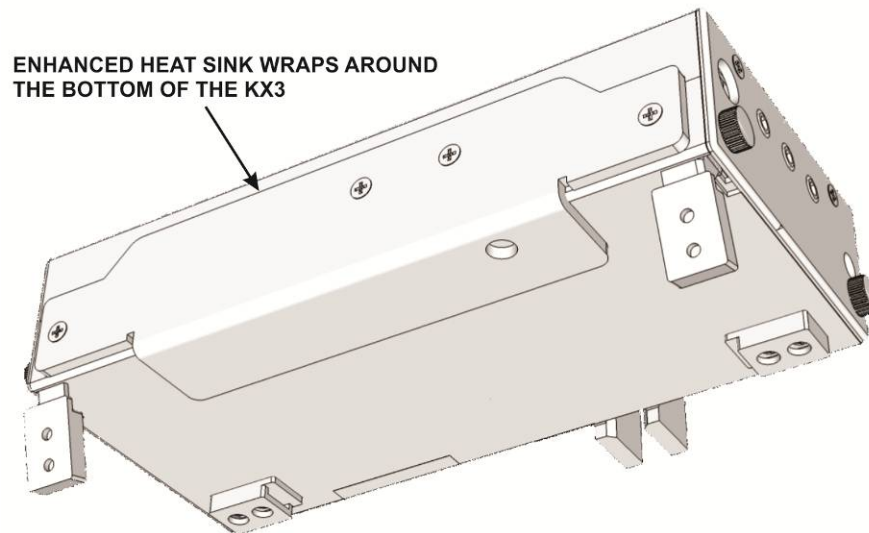

Figure 1. Enhanced Heat Sink Installed.

The enhanced heat sink replaces the existing heat sink. Do not attempt to use both heat sinks. Any possible improvement in performance is negligible and may actually reduce the effectiveness of the enhanced heat sink.



This kit includes longer screws as needed to install the enhanced heat sink.

Installing the Heat Sink

Tools Required

1. #1 size Phillips screwdriver. To avoid damaging screws and nuts, a power screwdriver is *not* recommended.
2. Long nose pliers.
3. Sharp tool such as a hobby or pen knife.

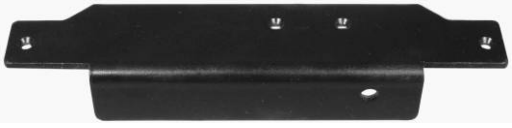
Parts Supplied

ILLUSTRATION	DESCRIPTION	QTY.	ELECRAFT PART NO.
	Enhanced Heat Sink (wrapped)	1	E850677
	Thermal Pad  Handle with Care. Do not remove the protective film from either side until instructed to do so.	1	E100546

KX3HSMDKT HDWR BAG E850676 (Envelope)

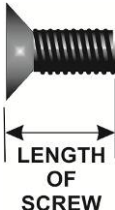
ILLUSTRATION	DESCRIPTION	QTY.	ELECRAFT PART NO.
	4-40 3/8" (9.5mm) Black Flat Head Screw	2	E700176
	4-40 5/8" (15.9mm) Black Flat Head Screw	1	E700307
	4-40 5/16" (7.9mm) Black Flat Head Screw	1	E700249

Procedure

- Disconnect all cables attached to the KX3 and remove the KXPD3 paddles if installed.
- Open the KX3 just as you would to install or remove batteries (see *Internal Batteries* in your Owner's Manual for details about how to do this).
- Remove the internal batteries, if present. (This is always good practice when working inside your KX3.)

Remove Original Heat Sink

⚠ CAUTION

This procedure does not require you to touch any ESD sensitive components if you follow the steps, but avoid the temptation to touch the exposed circuit boards unless you follow the recommendations under *Preventing Electrostatic Discharge Damage* on page 9.

- Remove the four screws to release the original heat sink (see Figure 2). Note that two screws thread into nuts with captive washers on the power transistors. Hold these nuts with your long nose pliers to avoid dropping them into the KX3. Keep the two nuts with captive lock washers. They will be replaced later. The screws will not be used. Longer screws are provided in the kit to replace them. Set the old heat sink aside. It will not be replaced.

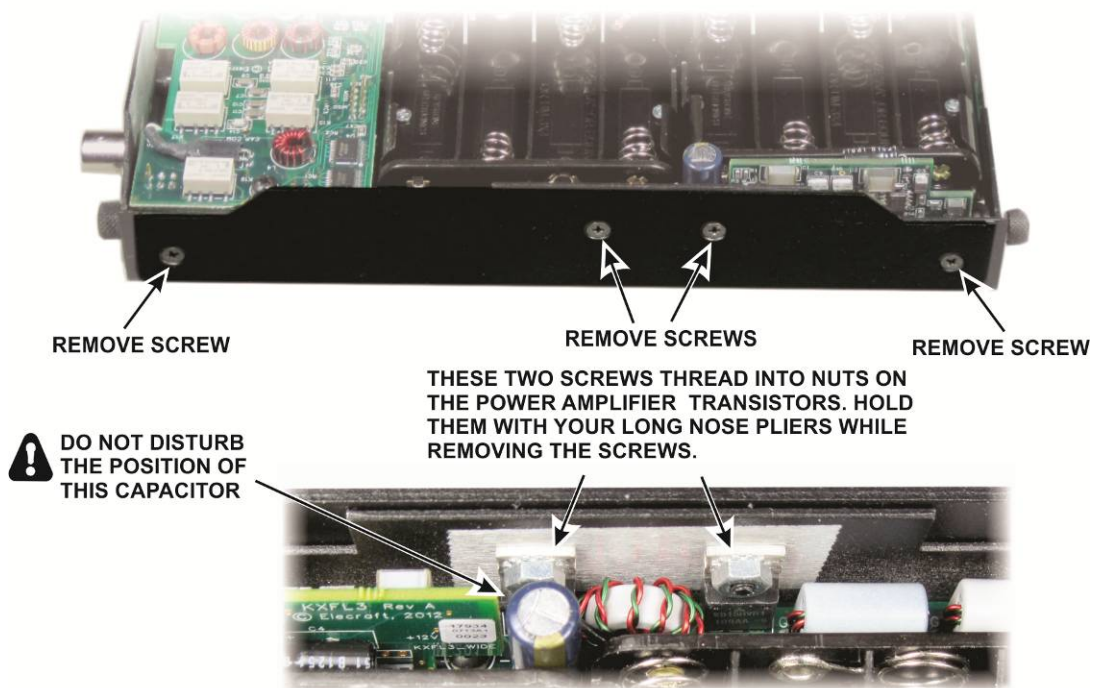

Figure 2. Removing Original Heat Sink.

Installing the Enhanced Heat Sink

If you haven't done so already, remove the new heat sink from the paper wrapper. The side of the heat sink that will face the KX3 has been masked keep it free of the powder coating (see Figure 3). Remove the masking tape covering this area of the heat sink. The tape is strong. You can peel up one corner with a sharp tool and then pull the tape off of the metal as shown in the figure.

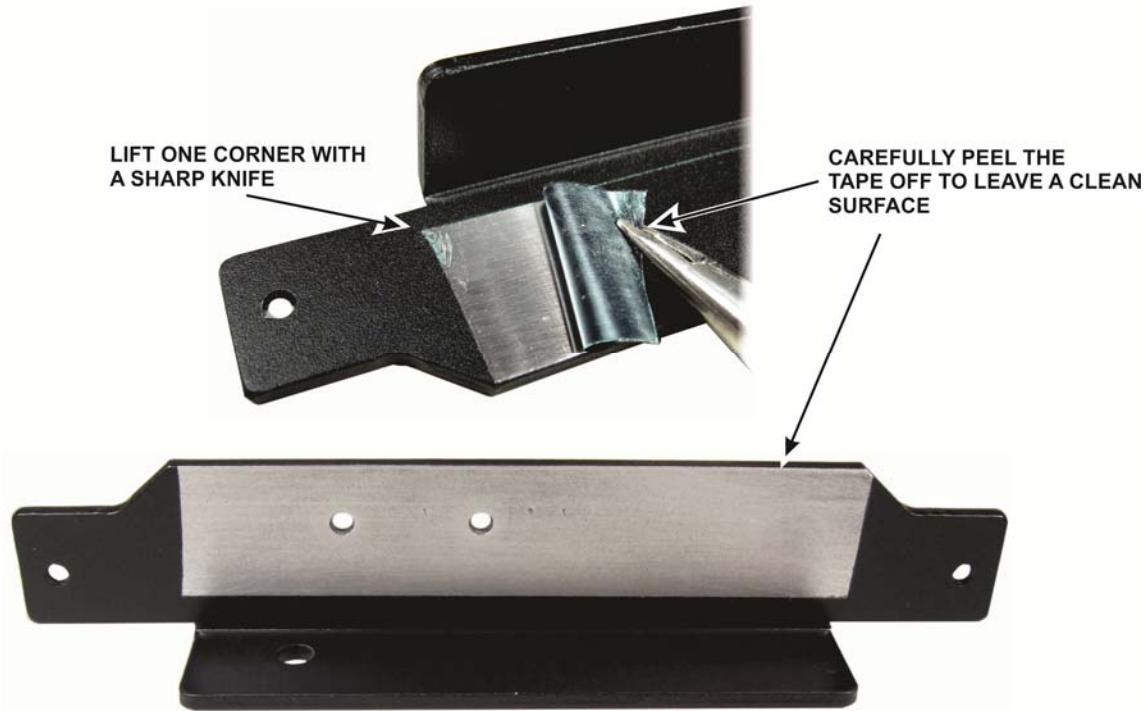

Figure 3. Removing Tape from the Heat Sink.

Lay the heat sink down on your work table as shown in Figure 4 with the two 4-40 3/8" (9.5mm) black flat head screws in the holes as shown. The screws will assist in aligning the thermal pad over the bare metal area.

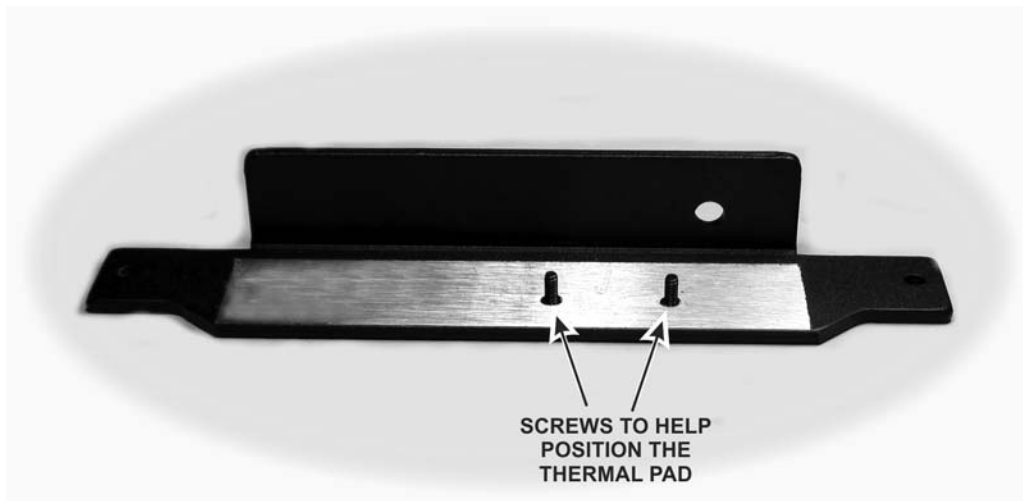

Figure 4. Heat Sink Ready for Thermal Pad.

Locate the thermal pad and carefully separate the white protective coating from one side. There are three layers: a clear plastic protective film, the thermal pad itself, and a white plastic protective film. The three layers are shown in Figure 5. **Remove only the white plastic protective film to expose the adhesive surface underneath.** A sharp knife is handy for separating the layers. Work carefully to avoid separating the clear plastic protective film from the thermal pad. The thermal pad wrinkles easily if it is allowed to separate from the clear plastic, and will not work properly unless it remains flat.



Figure 5. Preparing the Thermal Pad.

Carefully position the thermal pad on the heat sink as shown in Figure 6. Be sure the adhesive side is against the metal and the clear plastic protective film is facing upward. Rub the center area of the thermal pad to help it adhere to the metal.

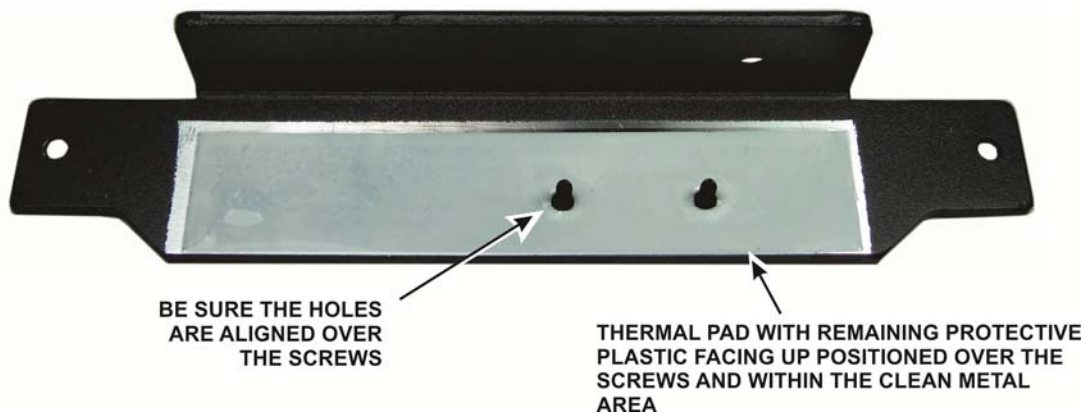

Figure 6. Placing the Thermal Pad on the Heat Sink.

Remove the clear plastic protective cover from the thermal pad (see Figure 7). Be sure the thermal pad remains attached to the metal and does not fold or wrinkle.

⚠ Keep the exposed adhesive surface of the thermal pad clean.

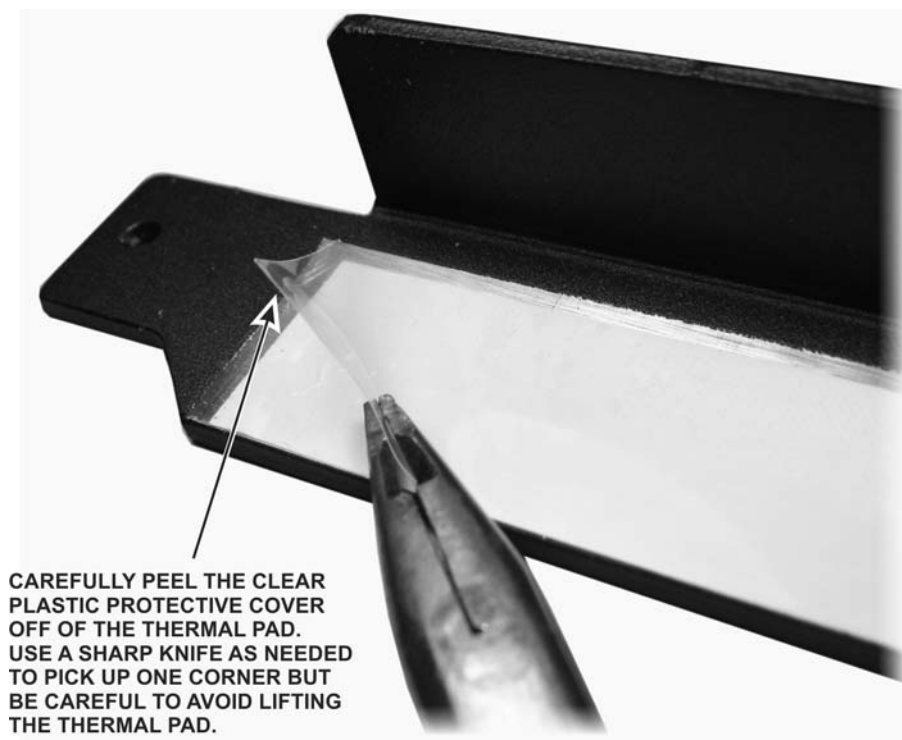

Figure 7. Removing the Clear Plastic Protective Cover from the Heat Sink.

□ Close the KX3 enclosure and stand it vertically as shown in Figure 8. You don't need to tighten the thumb screws yet. Attach the cover with the black flat head screws as shown. Carefully place the heat sink on the enclosure and secure it with the screws shown. The thermal pad presses against the powder coating on the bottom cover. Although the thermal pad is tacky, the heat sink can be moved as needed to align the screw holes.



IF THE KX3 IS EQUIPPED WITH THE OPTIONAL KXFL3 MODULE, ONLY INSTALL THIS SCREW PART WAY AS SHOWN TO AVOID POSSIBLE DAMAGE TO THE KXFL3 BOARD. IT WILL BE TIGHTENED LATER.

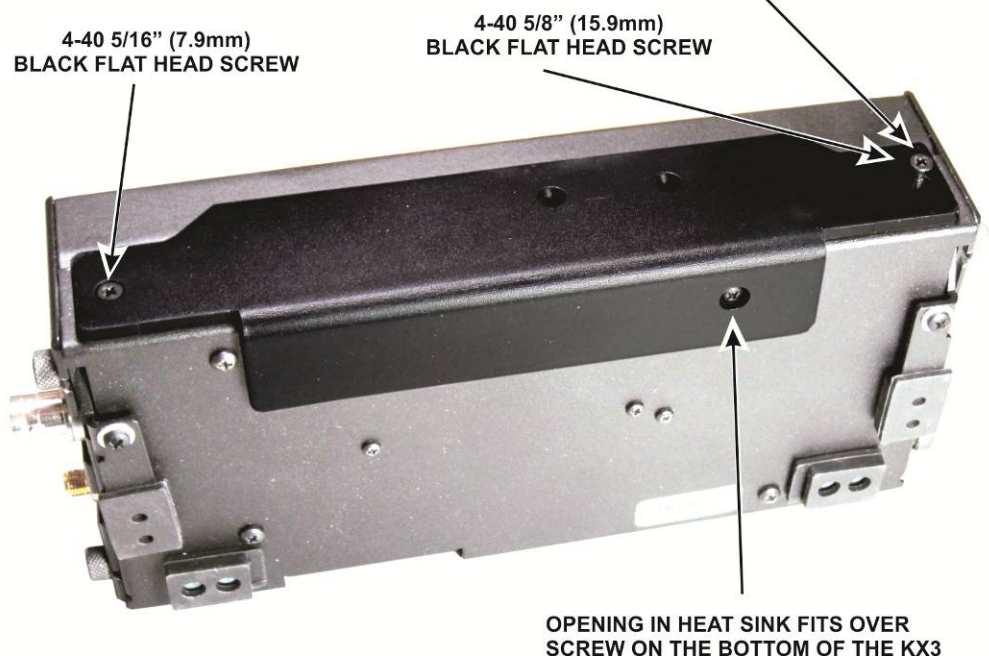

Figure 8. Mounting the Enhanced Heat Sink on the KX3.

Place the KX3 on its feet and open the top cover again. Tighten the remaining mounting screw you started in the previous step. If the KXFL3 module is installed be sure the screw passes through the opening in the KXFL3 board as shown in Figure 9. If it strikes the module pc board, reseal the module in the connector on the KX3 main board so the hole lines up with the screw. The purpose of this screw is only to ensure the module is not jarred loose by rough handling of the KX3.

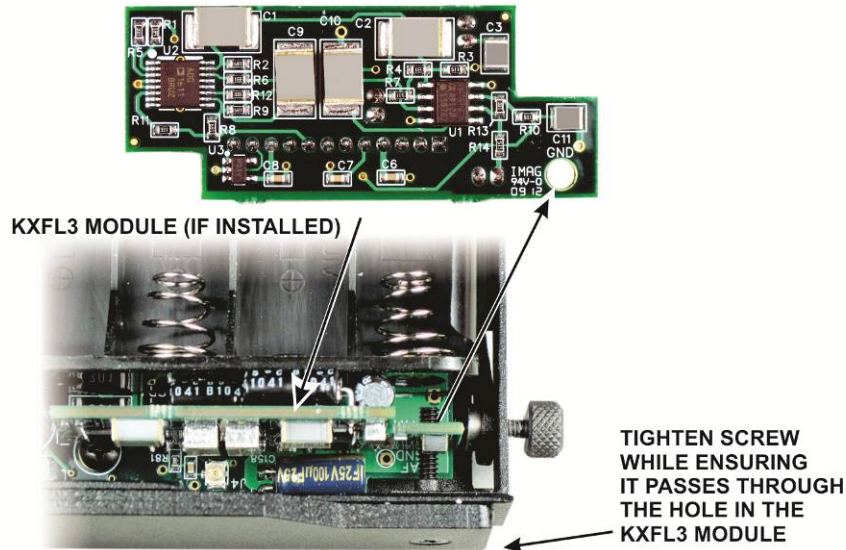

Figure 9. Tightening the Remaining Heat Sink Mounting Screw.

Install the screws to attach the power transistors to the case as shown in Figure 10, using the two captive lock washer nuts you removed earlier.

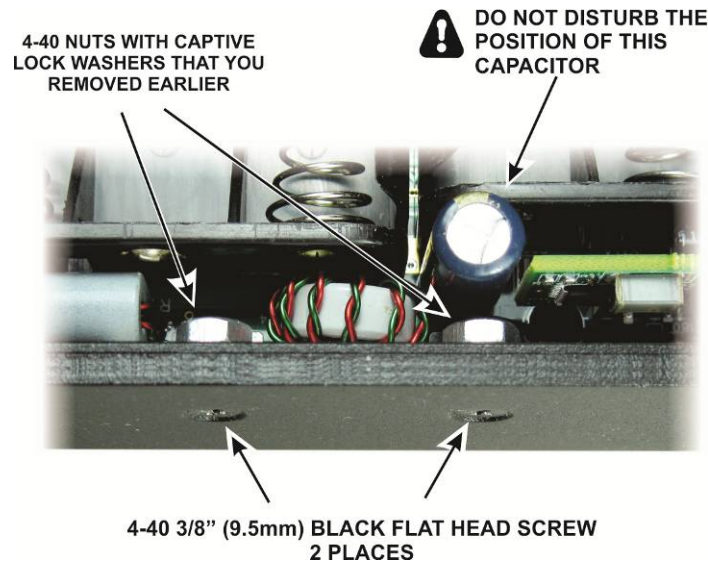

Figure 10. Installing the Transistor Mounting Screws.

Replace the batteries (if applicable) and close your KX3.

That completes the installation of the enhanced heat sink.

Preventing Electrostatic Discharge Damage

ESD damage may occur with static discharges far too little for you to notice. A damaged component may not fail completely at first. Instead, the damage may result in below-normal performance for an extended period of time before you experience a total failure.

We strongly recommend you take the following anti-static precautions (listed in order of importance) to ensure there is no voltage difference between the components and any object that touches them:

- Wear a conductive wrist strap with a series 1-megohm resistor that will constantly drain off any static charge that accumulates on your body. If you do not have a wrist strap, touch a ground briefly before touching any sensitive parts to discharge your body. Do this frequently while you are working. You can collect a destructive static charge on your body just sitting at the work bench.

WARNING

DO NOT attach a ground directly to yourself without a current-limiting resistor as this poses a serious shock hazard. A wrist strap must include a 1-megohm resistor to limit the current flow. If you choose to touch an unpainted, metal ground to discharge yourself, do it only when you are not touching live circuits with any part of your body.

- Use a grounded anti-static mat on your work bench (see below).
- If you pick up a pc board that was not placed on an anti-static mat or in an anti-static package, touch first a ground plane connection on the board such as a connector shell or mounting point.
- If you use a soldering iron to work on a circuit board, be sure your iron has an ESD-safe grounded tip tied to the same common ground used by your mat and wrist strap.

Choosing an Anti-Static Mat

An anti-static mat must bleed off any charge that comes in contact with it at a rate slow enough to avoid a shock or short circuit hazard but fast enough to ensure dangerous charges cannot accumulate. Typically, a mat will have a resistance of up to 1 Gigaohm (10^9 ohms). Testing a mat requires specialized equipment, so we recommend that you choose an anti-static mat that comes with published resistance specifications and clean it as recommended by the manufacturer. Testing has shown that many inexpensive mats that do not specify their resistance have resistance values much too high to provide adequate protection, even after they were cleaned and treated with special anti-static mat solutions.

Suitable anti-static table mats are available from many sources including:

- U-line (Model 12743 specified at 10^7 ohms)
- Desco (Model 66164, specified at 10^6 to 10^8 ohms)
- 3M™ Portable Service Kit (Model 8505 or 8507, specified at 10^6 to 10^9 ohms)